

FUSELAGE ASSEMBLY FOURTH SECTION (OF FOUR)

SEAT BELT ATTACH POINTS

The hard points for the seat belt anchor installations should all have been inserted during the preceding fuselage assembly operations, and should be ready for the following steps. If any of the areas referred to in the following steps do not have the required high density core materials installed, and the reinforcing BID layers applied, then these should be done at this time. Cable sections for the shoulder belts should be fabricated at this time. Use left over rudder cable sections and make loops at each end with cable thimbles and nicropress cable crimps, about 40 inches long. Make the loop at one end through the anchor bolts for the shoulder straps that should have been installed in the bulkhead behind the baggage area. The straps can be assembled at this time using the supplied ¼ inch bolts, castellated nuts, cotter pins and washers. It might be a good idea to put the straps in a paper or plastic bag at this time to avoid tangling or soiling them in subsequent operations.

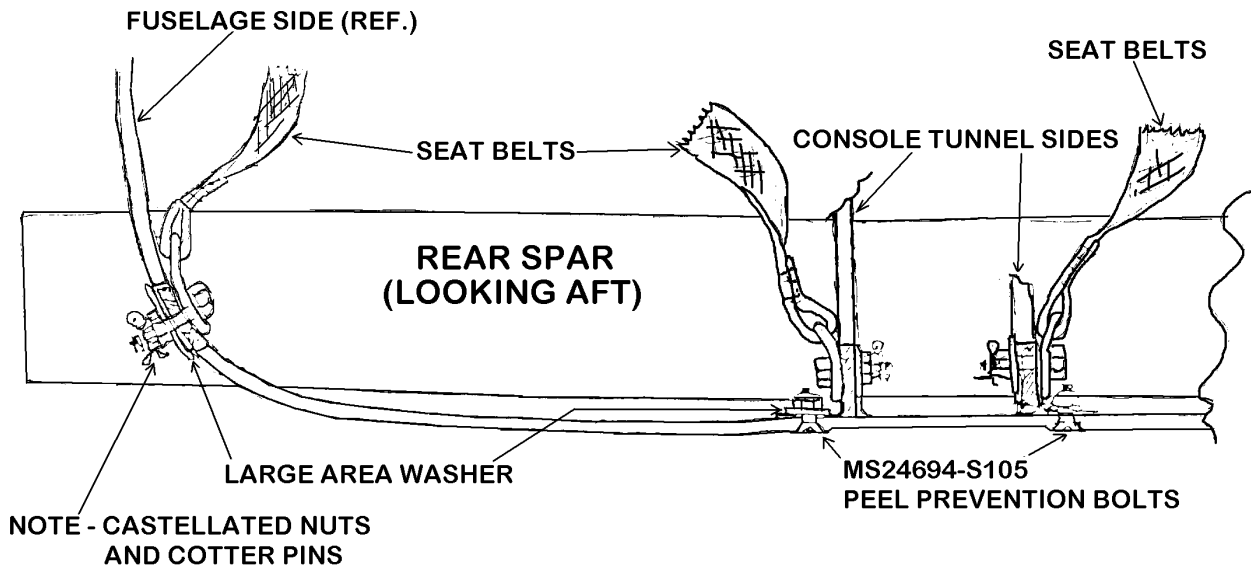

FIGURE - Seat belt attachment points

The hard points for the inner lap belt attachment are located in the rear lower corner of the control console tunnel sides. Drill a ¼ inch hole through the center of this hard point, and another ¼ inch hole vertically down through the fuselage bottom, outside of the control tunnel area about a half inch outboard of the wall, through the 8 layer BID reinforcement applied in an earlier step. From the bottom of the fuselage, countersink for the MS 24694-S 105 bolt, and install with large area washer and lock nut (this is a peel preventative against any upward forces on the belt). Bolt the appropriate belt end clevis with another ¼ inch bolt, castellated nut and washer combination through the hard point in the tunnel side wall, and cotter key the castellated nut to prevent belt movement from loosening the nut.

The hard point for the outer lap belt section is through the fuselage wall, just ahead of the rear spar. Use a large area washer on the outside of the fuselage (the wing and fairing assembly will cover this area, so there is no requirement for a flush assembly). Again use ¼ inch bolts, with a cotter pin and castellated nut, to ensure against loosening as the belt is moved about. The enclosed figure should help clarify these instructions.

SEAT BOTTOM ASSEMBLY

The seat bottom can be tailored to individual requirements, but the enclosed instructions describe the method that has worked well on the factory airplane. The seat panels should be fabricated with the ¼-inch foam material supplied, or any other similar core material desired. Use a straight edge across the top of the spar box, and angle down, resting on the top of the stiffening flange of the main gearbox, to locate a point on the rear spar. Draw a line on the front face of the rear spar at this level, and construct at least a ½ inch wide ledge at this level to support the rear edge of the seat panel. This line should be very close to the fuselage bottom at this point, and you may just be flattening out the inner fuselage curvature, but the shelf should be used to create a straight level support for the aft edge of the seat panel. Remember, in setting up the seat proportions, that it is a lot easier to add padding, than it is to look for more headroom at a later date. Some scrap pieces of foam can be bonded into place, and shaped, and with a 2-ply BID covering would be an ideal selection to provide this support for the aft edge of the seat panel.

Make the seat bottom core section a little oversize, and cover with two ply BID. Angle the front section such that it will lay flat on the top of the spar box. Cut a generous opening to allow full control stick travel, and dress the edges of the opening with FLOX. Trim the edges of the panel to fit closely into place against the tunnel sides in the center, and the curved fuselage sides on the outer edges, to keep it from shifting position in use. Bond a couple of blocks on the underside in front, close to the spar box aft face, to keep the panel from shifting forward. Reference the enclosed figure to clarify any questions.

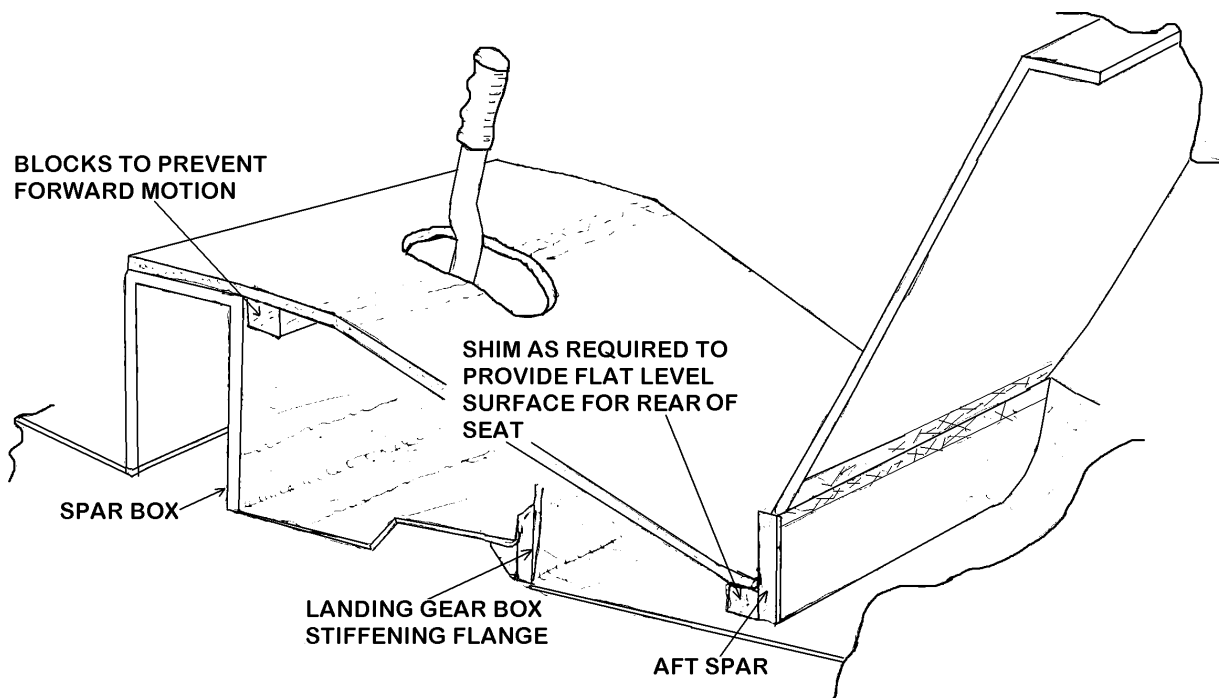

FIGURE - Seat bottom fabrication and assembly

PITCH TRIM CONTROL

Although many of our builders are opting for electrical remote trim systems (MAC or similar) the default pitch trim control for this aircraft is implemented using a Bowden wire cable back to a moveable tab on the elevator, and the hardware to implement this system is included in the kit. Remember that tab movement is the reverse of control surface movement. That is - the tab moves downward to bring the nose up, and vice versa. Route the cable under the horizontal stabilizer and into the fuselage section. It is recommended that you fabricate a "fairlead" type penetration into the fuselage section using a short length of the nylon tubing to permit the Bowden housing to slide in and out as the elevator is actuated (see figure for a rough idea of how this is accomplished). Roughly route the cable through the fuselage, up into the control console tunnel between the seats. Avoid any potential interference with the moving flight controls.

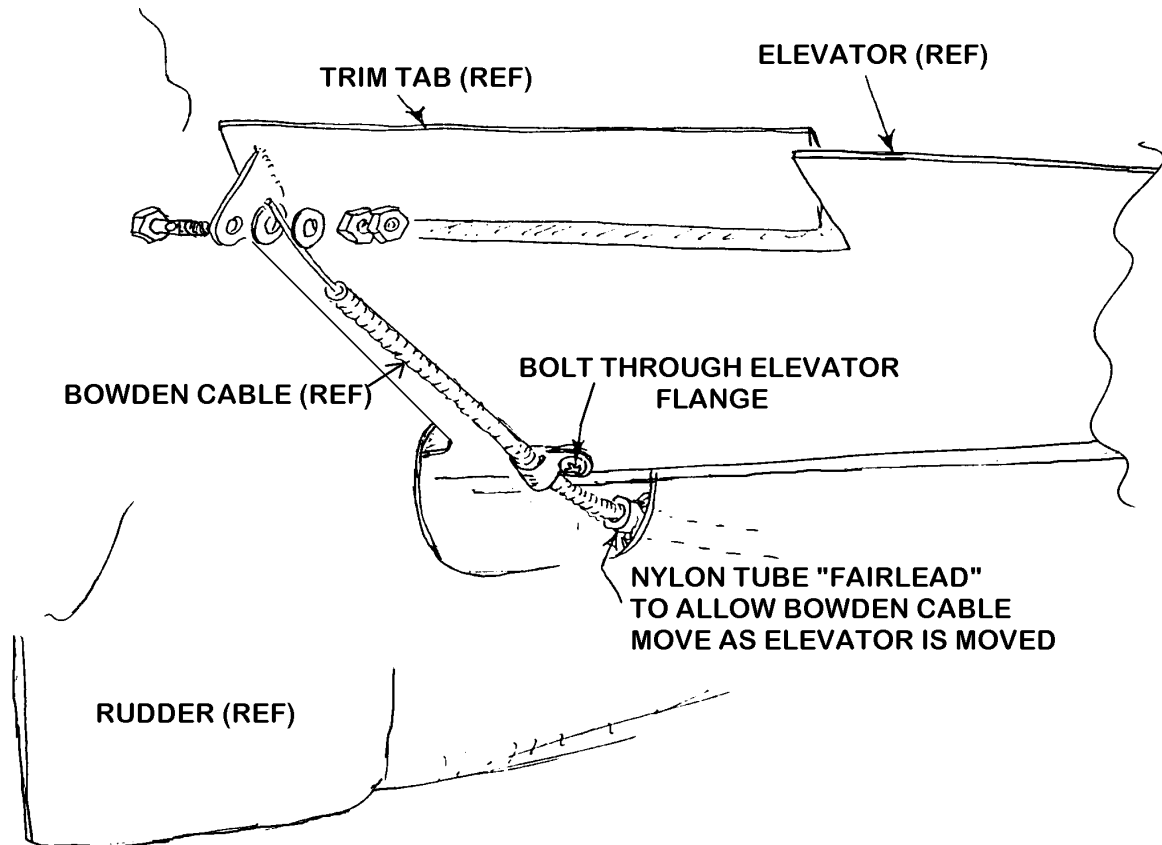

FIGURE - Trim tab end of trim system installation

Attach the free end of the central wire to the trim tab control arm. Use one of the "terminal" assemblies supplied (a short #10 hex head bolt with a transverse hole drilled through about 3/16 inch from the head, packaged with two washers and two hex nuts). The transverse hole is sized for a 1/16-inch wire and must be reamed out with a 5/64-inch drill to accept the bowden wire in the kit. This will still be a close fit so the end of the wire must be deburred to fit in the hole. The bolt is passed through the hole in the control arm, then the first washer installed, the wire threaded through the hole, the second washer installed, and the first nut tightened into place with the wire positioned as desired. It is a good idea to apply a small drop of adhesive on the threads, and tighten the second "jam" nut into place.

Make sure enough of the center wire is exposed from the Bowden housing to assure full adjustment of the tab, and anchor the bowden housing to the lower surface of the elevator, at the lower flange at the front edge of the elevator. Drill through this flange and use a #8 screw with a loose nut plate up in the recess (The nut plate need not be riveted in, the elevator flange will prevent it from turning. Use a cable clamp that will grip the housing firmly and prevent slipping fore and aft. If epoxy or other adhesive is used to secure this mounting, the bowden housing must be sealed with tape to prevent seepage from locking up the center wire.

Work the elevator up and down through full travel and assure no binding of any of the free movement, and clear any potential conflicts.

Fabricate a control handle per the sketch below, from a remaining piece of 1/16-inch aluminum sheet, or procure equivalent material locally. The lower hole should be about as close to the pivot hole as will provide clearance for the sets of bolts and washers (about 3/4 in.). The upper hole for the handle, should be at least twice this value to reduce the sensitivity of this adjustment. Mock up the lever assembly and locate the appropriate point on the inner surface of the tunnel wall roughly opposite of the flap handle pivot point. Simulate operation from this pivot point, and assure that none of the components of this assembly will interfere with the other control linkages. Although the loads are light on this control, it is probably desirable to prepare a local "hard point" for the pivot bolt in the passenger side tunnel side, at the desired pivot position. Cut through the outer skin of the sandwich material and either insert a disc of phenolic or fill the cavity with dry MICRO/FLOX. Apply a patch of 2 ply pre-wetted BID with at least a half inch overlap beyond the edges of the cut out. Drill a 3/16-pivot hole through the "hard point" in the selected location after the resin cures.

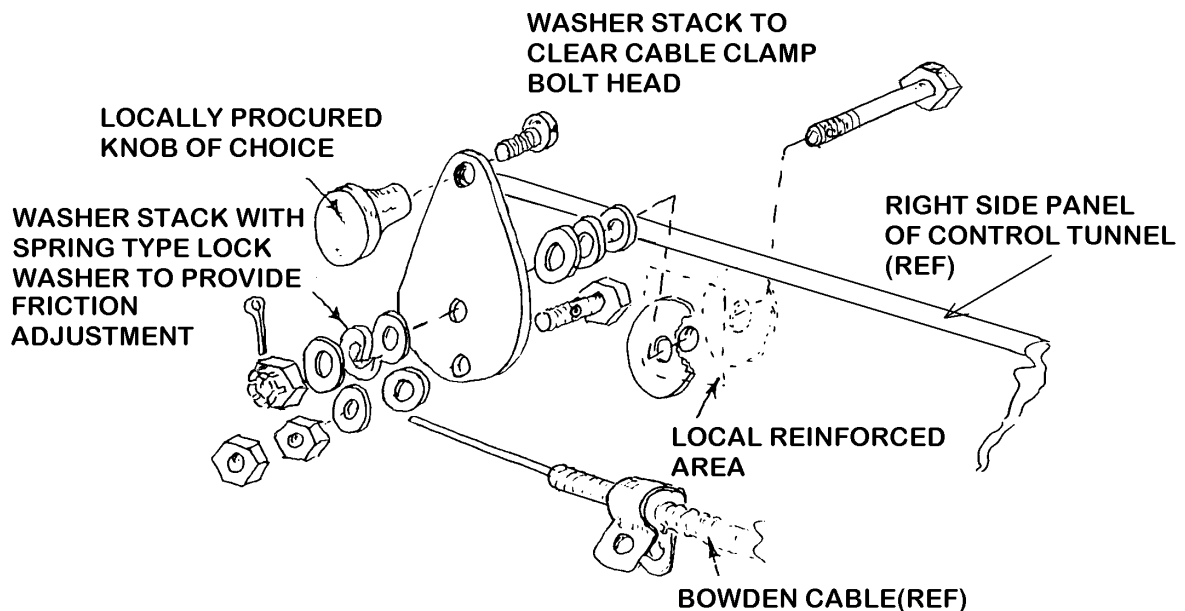

FIGURE - Trim actuation lever - suggested assembly

Attach the free end of the Bowden center wire to the lower hole in the lever using a "terminal assembly" as before at the rear control horn. Orient the assembly such that the bolt head is toward the tunnel wall. Insert an appropriate length #10-32 bolt (stack the total assembly for best fit) through the pivot hole with a large area washer on each side of the sandwich panel. Add three smaller diameter washers to provide clearance for the "terminal assy." bolt head, and put on the lever. Assemble another washer, a spring lock washer, and another plain washer. Install a castellated nut and tighten to desired friction level, and install cotter pin. Anchor the Bowden housing to the tunnel inner wall with a cable clamp about 5 to 8 inches from the lever, make sure sufficient bare wire is open to permit travel of the control arm.

Set the elevator at the neutral position, and set the trim tab in a neutral trail position on the elevator. Loosen the wire clamping on the lever, and set the lever in a vertical position. Re clamp on the wire, and jam nut on the "terminal assembly", and secure with a dab of epoxy or other adhesive on the threads.

Anchor the cable housing at frequent intervals (if FLOX or BID is used to anchor the cable, be sure to wrap the cable outer shell with tape to prevent the resin from seeping in and locking the cable in place).

CONTROL CONSOLE COVER

The control console cover is a molded assembly furnished with the kit. Clean up the edges and verify proper clearance for the control levers that protrude from this cover. A cutout will have to be made for the elevator trim control. Installation is accomplished by simply setting the cover in place and the seat pan or cushions will sit on the flanges holding it in place.